

Flow Sensor

FFAF004

Part Number

UniFlow



- Highest precision of its class
- Installation in any position
- Measurement independent of flow direction
- Simple operation via the display
- Temperature of the medium: 0 ... 100° C (140° C for 24 hours without current measurement)

wenglor UniFlow flow sensors measure the flow rate of aqueous and oily media in closed piping systems. UniFlow flow sensors are very easy to operate thanks to the integrated display. The highly visible switching status display enables the rapid localization of affected sensors for maintenance processes.

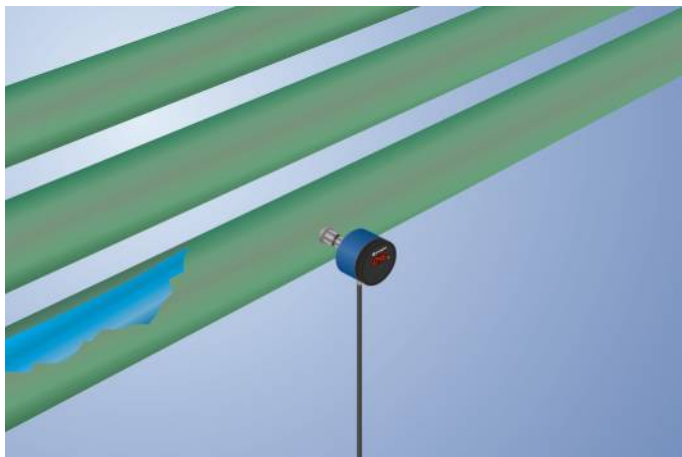

Technical Data

Sensor-specific data

Measuring Range	15...200 cm/s
Adjustable Range	15...200 cm/s
Medium	Water
Measuring error	2 %
Switching Hysteresis	5 %
Temperature gradient	30 K
Response time in case of temperature jump	10 s

Environmental conditions

Temperature of medium	0...100 °C
Temperature of the medium, short-term	140 °C
Ambient temperature	-20...70 °C
Mechanical Strength	60 bar
EMC	DIN EN 60947-5-9
Shock resistance per DIN IEC 68-2-27	50 g / 11 ms
Vibration resistance per DIN IEC 60068-2-6	20 g (10...2000 Hz)

Electrical Data

Supply Voltage	16...32 V DC
Current Consumption (U _b = 24 V)	60 mA
Switching Outputs	1
Response Time	1...5 s
Switching Output/Switching Current	< 250 mA
Switching Output Voltage Drop	< 2 V
Short Circuit Protection	yes
Reverse Polarity Protection	yes
Protection Class	III

Mechanical Data

Setting Method	Menu
Housing Material	PBT; PC; FKM
Material Control Panel	Polyester
Material in contact with media	1.4435; 1.4404; FKM
Degree of Protection	IP67 *
Connection	M12 × 1; 4-pin
Process Connection	G 1/2"
Process Connection Length	47 mm
Probe Length	10 mm

Safety-relevant Data

MTTFd (EN ISO 13849-1)	1436,42 a
------------------------	-----------

PNP NO/NC switchable	<input checked="" type="checkbox"/>
Connection Diagram No.	532
Control Panel No.	A03
Suitable Connection Technology No.	2
Suitable Mounting Technology No.	903 905

* Tested by wenglor

Complementary Products

Seal G1/2" ZH5G002

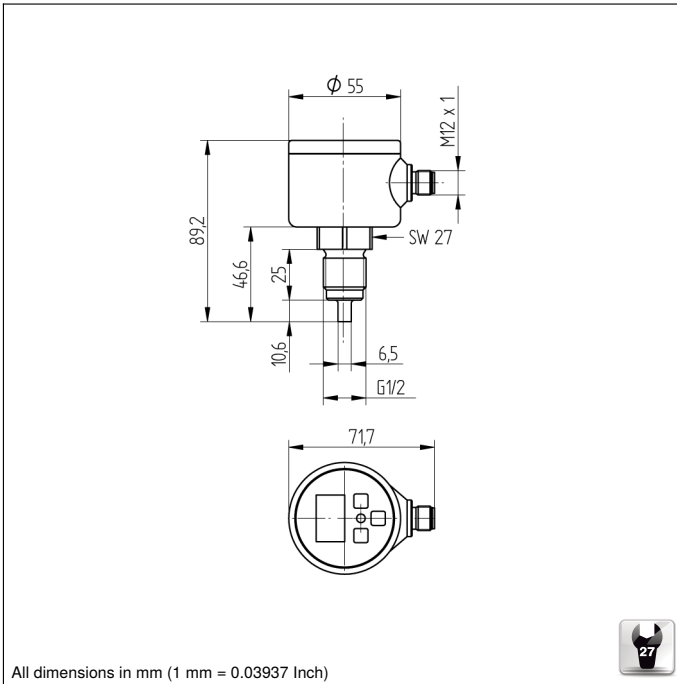

Ctrl. Panel

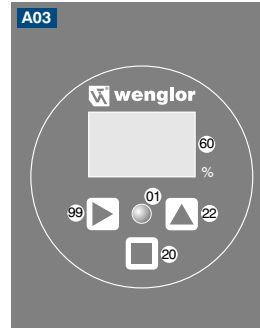

- 01 = Switching Status Indicator
- 20 = Enter Button
- 22 = UP Button
- 60 = Display
- 99 = Right button

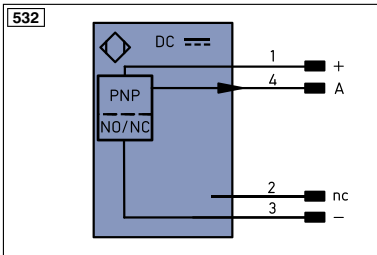

Legend

+	Supply Voltage +	PT	Platinum measuring resistor	ENa	Encoder A
-	Supply Voltage 0 V	nc	not connected	ENb	Encoder B
~	Supply Voltage (AC Voltage)	U	Test Input	AMIN	Digital output MIN
A	Switching Output (NO)	U	Test Input inverted	AMAX	Digital output MAX
Ā	Switching Output (NC)	W	Trigger Input	AOK	Digital output OK
V	Contamination/Error Output (NO)	O	Analog Output	SY In	Synchronization In
ṽ	Contamination/Error Output (NC)	O-	Ground for the Analog Output	SY OUT	Synchronization OUT
E	Input (analog or digital)	BZ	Block Discharge	Out	Brightness output
T	Teach Input	AW	Valve Output	M	Maintenance
Z	Time Delay (activation)	a	Valve Control Output +		
S	Shielding	b	Valve Control Output 0 V		
RxD	Interface Receive Path	SY	Synchronization		
TxD	Interface Send Path	E+	Receiver-Line		
RDY	Ready	S+	Emitter-Line		
GND	Ground	≡	Grounding		
CL	Clock	SnR	Switching Distance Reduction		
E/A	Output/Input programmable	Rx+/-	Ethernet Receive Path		
	IO-Link	Tx+/-	Ethernet Send Path		
PoE	Power over Ethernet	Bus	Interfaces-Bus A(+)/B(-)		
IN	Safety Input	La	Emitted Light disengageable		
OSSD	Safety Output	Mag	Magnet activation		
Signal	Signal Output	RES	Input confirmation		
Bl_D+/-	Ethernet Gigabit bidirect. data line (A-D)	EDM	Contactur Monitoring		
EN0_9542	Encoder 0-pulse 0-0 (TTL)	ENa9542	Encoder A/Ā (TTL)		
		ENb9542	Encoder B/B̄ (TTL)		

Wire Colors according to DIN IEC 757

BK	Black
BN	Brown
RD	Red
OG	Orange
YE	Yellow
GN	Green
BU	Blue
VT	Violet
GY	Grey
WH	White
PK	Pink
GNYE	Green/Yellow

